

Installation and User Guide

Auteldac 4

ATEX / IEC Ex Approved
Hazardous Area Telephone



CONTENTS

1	PRODUCT DESCRIPTION.....	2
1.1	At a Glance	3
1.2	External Signalling	3
1.3	Dimensions	4
1.4	Related Standards and Regulations	5
1.5	Headset	7
1.6	Suitability for Use	7
1.7	Environmental Considerations	8
1.8	Recycling Information	8
2	INSTALLATION	8
2.1	Pre-installation	8
2.2	Protection Against Hazards	9
2.3	Preparation	10
2.4	Wall Mounting	11
2.5	Pole-side Mounting	12
2.6	Desk Mounting / Rake.....	13
2.7	Connections and Cabling.....	14
2.8	Option Settings	19
2.9	Assembly of Telephone on to Installed Base	20
2.10	Possible Operating Faults.....	21
3	OPERATION.....	22
3.1	Making and Receiving Calls.....	23
3.2	Last Number Redial	23
3.3	Recall Function	23
3.4	Programming	23
3.5	Secrecy or Mute Function	23
3.6	Headset Operation.....	24
4	MAINTENANCE.....	25
4.1	Procedures	25
4.2	Fault Finding & Field Repairs.....	25
5	CE DECLARATION	26

IMPORTANT

ALL POSSIBLE MEASURES MUST BE TAKEN TO ENSURE WATER, FLUID OR DUST DOES NOT CONTAMINATE THE INTERNAL COMPONENTS OF THIS TELEPHONE WHILST UNPACKING, PREPARING AND INSTALLING IT IN INCLEMENT WEATHER CONDITIONS OR BY NEGLIGENCE.

**FAILURE TO CARRY OUT THIS PRECAUTION
WILL INVALIDATE CERTIFICATION AND YOUR WARRANTY**

1 PRODUCT DESCRIPTION

ONE TOUCH DIAL MEMORY BUTTONS

Allows you to store up to 17 digits and dial them at the press of a single button.

STORE

Allows you to store up to 17 digits at the press of a single button.

R BUTTON

Recall button for use with switchboards and BT Select Services to recall or transfer a call to another number

LAST NUMBER REDIAL BUTTON

Press to redial the last number called (up to 32 digits)

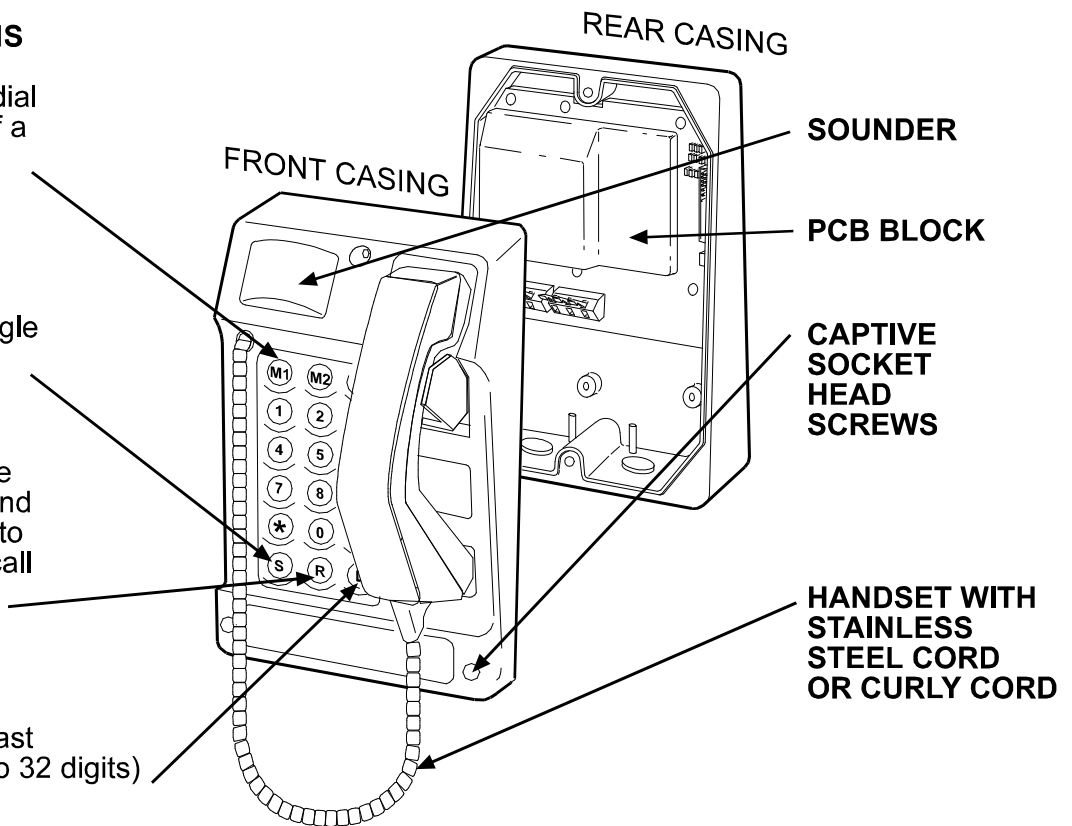

Figure 1 – Auteldac 4 Hazardous Area Telephone at a glance

1.1 At a Glance

Auteldac 4 is an Ex certified telephone built to withstand arduous industrial atmospheres and environmental extremes. Features include:

- Carbon loaded glass filled polyester body - rugged and corrosion free.
- ATEX / IEC Ex certified for safe operation in hazardous areas
- Rugged handset with curly cord or armoured stainless steel cord.
- Noise-cancelling handset option
- Weather resistant up to IP66
- Selectable Timer – can be set to go back on hook after 6-8 minutes
- Integral 90dBA ringer with volume adjustment.
- Selectable dial and recall modes
- External signalling facilities (see below)
- Parallel telephone line connection terminal block
- One touch dial memories (18 button version only)
- Hearing aid compatible inductive coupling as standard
- Available in a range of keypad options including CB
- Headset option available.

1.2 External Signalling

The Auteldac 4 provides a galvanically isolated, volt-free contact for an external signalling device, which opens and closes in step with the cadence of the ringing signal from the exchange. The contacts are rated at 240V a.c. rms at 5A. continuous resistive. This signalling device is referred to as LOAD1 in the cabling section.

An optically isolated, volt-free contact is additionally provided to indicate the state of the hook switch of the telephone instrument. The contacts are rated at 250V a.c. rms at 150mA continuous. This signalling device is referred to as LOAD2 in the cabling section.

(See section 2.7 for more details on how to connect these optional facilities.)

1.3 Dimensions

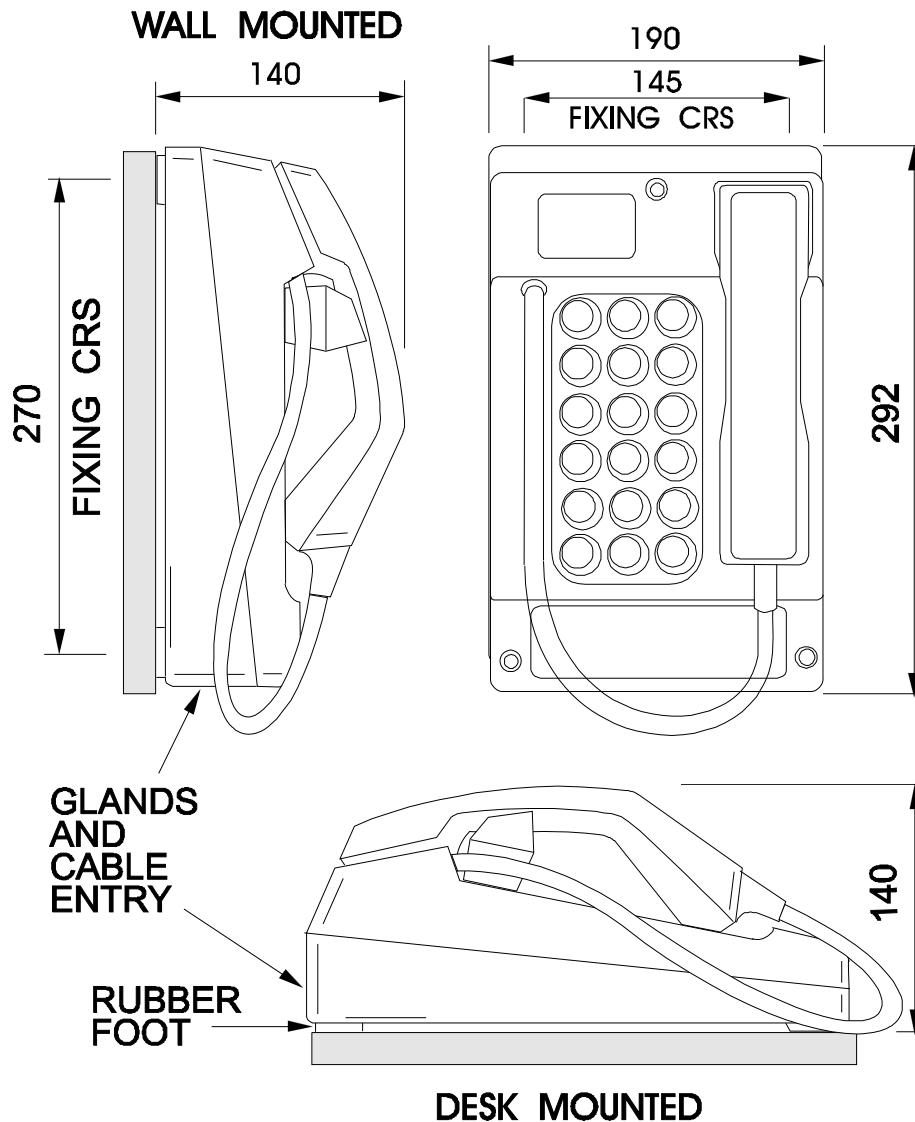

Four 7mm-clearance holes in the Rear Casing (outside the environmental seal) allow it to be screwed or bolted to a wall, or to a pole-side mounting kit (part no 100-02-0208-001).

The holes are arranged in a rectangle, as follows -

- Horizontal separation between centres: 145.0mm
- Vertical separation between centres: 270.0mm. The lower pair are about 10mm up from the bottom edge of the unit.

Handset cord lengths:

Standard curled cord: 320mm extending to 1m.

Standard stainless steel cord: 755mm

Other cord lengths are available as special options: contact GAI-Tronics for details.

1.4 Related Standards and Regulations

Auteldac 4 is fully compliant with the following:

1.4.1 Safety Testing to:

EN60950:2000 – Specification for information technology equipment, including electrical business equipment.

1.4.2 EMC Testing to:

EN55022:1998 – Information technology equipment. Radio disturbance characteristics.

EN55024:1998 – Information technology equipment. Immunity characteristics.

1.4.3 Transient Protection Testing to:

ITU-T recommendation K.21 (10/2000) - Enhanced surge protection.

1.4.4 Telephony Testing to:

I-CTR37 & CTR38 pan-European ETSI telephony standards. The Auteldac 4 has been designed for pan-European single terminal connection to the Public Switched telephone Network (PSTN). However, due to differences between the individual PSTNs & PABXs provided in different countries, this does not, of itself, give an unconditional assurance of successful operation on every PSTN or PABX termination point.

ETS 300 381 – Telephony for hearing impaired people; Inductive coupling of telephone earphones to hearing aids.

1.4.5 ATEX Hazardous Area Certification to:

EN50014:1998– Electrical apparatus for potentially explosive atmospheres. General requirements.

EN60079-7 : 2003 (IEC 60079-7 : 2001 Edition: 3) Electrical apparatus for explosive gas atmospheres - Part 7: Increased safety 'e'

EN50020:2002 – Electrical apparatus for potentially explosive atmospheres. Increased safety “i”.

EN50028:1987 – Electrical apparatus for potentially explosive atmospheres. Encapsulation “m”.

1.4.6 Environmental Testing to:

EN60529:1992 – Degrees of protection provided by enclosures.

1.4.7 European Directives:

1999/5/EC – European Radio Equipment & Telecommunications Terminal Equipment Directive.

94/9/EC - ATEX Product Directive.



This mark indicates compliance with the following directives for this product;

R&TTE Directive 1999/5/EC

ATEX Product Directive 94/9/EC

Ex II 2 G

Ex e ib mb IIC T5 (-20°C ≤ T_a ≤ 50°C)

Ex e ib mb IIC T4 (-20°C ≤ T_a ≤ 55°C)

Baseefa03ATEX0617



Suitable for inductively coupling to Hearing Aids having a 'T' switch position. Use of this facility for any other purpose than that for which it was intended may cause degradation in quality of a connection.

Tested to ETS 300-381



The GAI-Tronics Quality Management System has been approved by LRQA to ISO9001-2000. Certificate No. 861888

1.4.8 IEC Ex Certification

Auteldac 4 complies with the following IEC standards:

IEC 60079-0 : 2000 Electrical apparatus for explosive gas atmospheres -
Edition: 3.1 Part 0: General requirements

IEC 60079-11 : 1999 Electrical apparatus for explosive gas atmospheres -
Edition: 4 Part 11: Intrinsic safety 'i'

IEC 60079-18 : 2004 Electrical apparatus for explosive gas atmospheres -
Edition: 2.0 Part 18: Construction, test and marking of type of protection encapsulation 'm' electrical apparatus

IEC 60079-7 : 2001 Electrical apparatus for explosive gas atmospheres -
Edition: 3 Part 7: Increased safety 'e'

Certification details:

IECEx BAS 05.0060

Ex e mb ib IIC T5 (-20°C ≤ T_a ≤ +50°C)

Ex e mb ib IIC T4 (-20°C ≤ T_a ≤ +55°C)

Headset

For models fitted with headset socket, use only GAI-Tronics ATEX headset part number 100-02-0598-001. See section 3.6 for operation.

NOTE:

GAI-Tronics only currently supply an ATEX certified headset. No IEC certified is available. IEC certification will be invalidated if an ATEX headset is connected.

Headset certification details:

 II 2 G

EEx ib IIC T4 (-20°C ≤ T_a ≤ 40°C)

TUV03ATEX2124

NOTE: the headset temperature class is T4 only. With the headset fitted, the temperature class of the complete instrument is that of the headset.

The headset must only be used in accordance with the supplied manufacturer's manual.

1.4.9 Optional Headset Extension lead

The standard headset cord is approximately 820mm long and can extend to approximately 2m (dependant on safe operating conditions.)

A separate headset extension lead is available as an optional extra (part No. 610-35-2036-001). This will allow the operator to use the headset over 6 metres away from the telephone unit. Note: Refer to section 2.2.1 for hazard warnings regarding long corded Headsets & handsets.

1.5 Suitability for Use

Auteldac 4 telephones are suitable for connection to the following types of telephone line:

- Direct analogue PSTN
- PABX
- Manual Exchange
- Private System

Connection may **NOT** be made to:

- Shared service (party) lines.
- Pay phone extension

Any usage other than those indicated will invalidate the certification of the telephone. Any cases of difficulty should be referred in the first instance to GAI-Tronics on +44 (0)1283 500500.

The telephone is supplied suitable for wall mounting and desk mounting.

IMPORTANT WARNING - Gland Specifications

Glands are not supplied. All glands and cables should comply with IP54 or better to meet 'Increased Safety' ('e' type) requirements. Only 'e' type glands and suitable cables should be used and must be fitted correctly. Note that the environmental rating of the telephone will not exceed that of the glands, i.e. in order to maintain an IP66 rating, glands must also meet IP66.

ALL POSSIBLE MEASURES MUST BE TAKEN TO ENSURE WATER, FLUID OR DUST DOES NOT CONTAMINATE THE INTERNAL COMPONENTS OF THE TELEPHONE WHILST UNPACKING, PREPARING AND INSTALLING IT IN INCLEMENT WEATHER CONDITIONS OR BY NEGLIGENCE.

FAILURE TO TAKE THIS PRECAUTION WILL INVALIDATE YOUR WARRANTY AND CERTIFICATION

The telephone body must **NOT** be opened, nor glands removed or cables disconnected unless all supplies to the telephone, including telephone cables and external devices have been isolated outside the hazardous area. Terminals for incoming cables are 'e' type and must be carefully connected so as to make an 'e' type termination.

The Code of Practice for 'e' type enclosures is specified in EN60079-14. The installer and all service personnel should be familiar with the relevant sections of these documents.

If only one gland entry is used, the sealing plug fitted to the second gland position should be left in place.

2.2 Protection Against Hazards

The Auteldac 4 telephone has been designed such that it does:-

- Not give rise to Physical injury or harm due to contact.
- Not produce excessive surface temperature, infra-red, electromagnetic or ionising radiation.
- Not have non-electrical dangers.

Note:- The above only applies provided the instructions, restrictions and warnings provided in this manual are complied with.

2.2.1 IMPORTANT WARNING:- Risk of Tripping or entanglement

For Auteldac 4 telephone versions supplied with long corded handset & headsets

Telephone location:-

Care must be taken when installing the telephone onto a wall, post or flat surface, to position the telephone so that the lower extremities of the stowed handset/headset cord do not pose an entanglement or tripping hazard.

Use of telephone:-

Some of the long corded (headset & handset) versions of the telephone can reach to over 5 metres away from the telephone position. Therefore caution and care must be taken when using the handset/headset at these extended distances, so that the user and other personnel or equipment in the vicinity is not impeded, trapped or entangled by the cord. Also, care must be taken to stow these long cord handset/headsets so they do not pose an entanglement or tripping hazard.

2.2.2 IMPORTANT WARNING: Ringer high noise level hazard:-

The telephone ringer can develop a sound level in excess of 90dBA @ 1 metre. Therefore, it is the installer's responsibility to take the necessary measure to comply with the European directive 2003/10/ec on the minimum health and safety requirements regarding the exposure of workers to the risks arising from physical agents (noise).

2.3 Preparation

1. Place the telephone on its base on a firm horizontal surface.
2. Using a 5mm Allen key, release the Front Casing from the Rear Casing. The screws are captive in the Front Casing.
3. Noting the positions, disconnect the keypad cable at the keypad. See figure 8, on Page 18.
4. Take care when removing the Front Casing from the Rear Casing and storing the Front Casing not to damage the internal electronics, specifically the headset switch terminals or connector PCB if fitted. To do so will violate the certification of the telephone product.
5. Remove the RED blanking plug from the cable entry hole leaving the EEx e certified (usually BLACK) blanking plug in situ.

NOTE: The EEx e plug must be used to seal the unused gland hole; failure to do so will invalidate the certification of the telephone product.

6. **If two metal glands are to be used:** remove one of the two Earth Bonding screws and re-assemble as shown in Figure 2 below to give an external stud. The earth stud is provided as suitable termination point to ensure earth continuity between cable glands. Note that it is the installer's responsibility to ensure the correct fitting of the glands (see section 2.1 above).

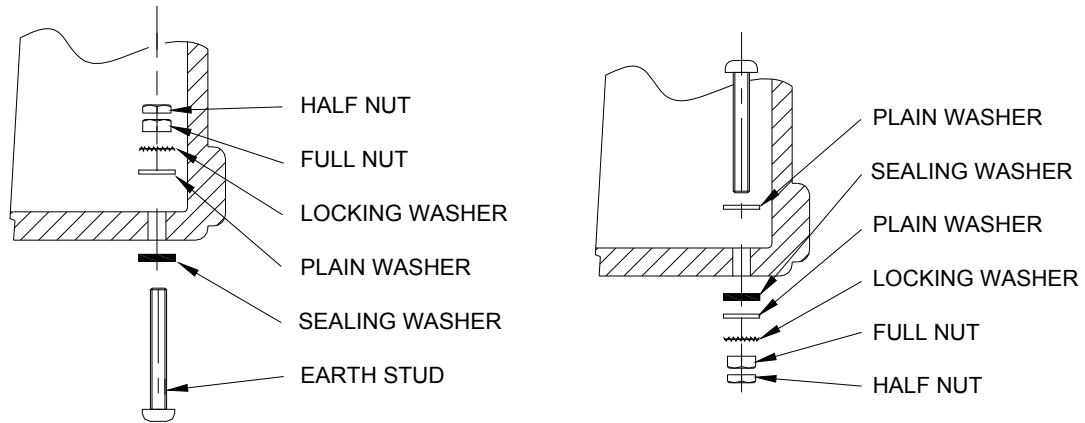

Figure 2 - Internal and external earth bonding stud arrangements

7. Select the appropriate size Ex gland for the cable used.
8. Take care when inserting the selected gland into the threaded cable entry hole. Follow the gland manufacturers instructions particularly with respect to sealing, installation and earthing.
9. After the glands have been fitted select the required mounting method and follow the appropriate instructions below.

2.4 Wall Mounting

To ensure weatherproof integrity when wall mounted, external cables should enter the enclosure from the bottom via the two 20mm gland entries provided.

IMPORTANT WARNING:

DO NOT DRILL ANY EXTRA HOLES AS THIS WILL INVALIDATE YOUR WARRANTY AND THE CERTIFICATE.

1. Remove rubber feet from the Rear Casing if fitted. Ensuring that the cable entries are at the bottom offer the Rear Casing up to the vertical surface and mark through the fixing holes.
Do not use the Rear Casing as a template to drill the holes. Work only from the marked positions.
2. Drill the holes in the vertical surface to suit the best method of fixing.
3. Ensure the Rear Casing is securely attached to the vertical surface using the four 7mm diameter screw holes provided. No sealing washers are necessary.

IMPORTANT: Do not use countersunk headed fixing screws. Only use round head, socket cap head or pan head screws. Take care not to over tighten the screws as doing so may damage the case and will invalidate your warranty and the certificate.

4. Pass the cable through the gland and tighten, following the gland manufacturer's instructions.
5. Continue the installation procedure with the connection of individual wires from the cable as described under sections 2.7 onwards.

2.5 Pole-side Mounting

(refer to Hazard warning in section 2.2.1)

Kit No 100-02-0208-001

This accessory kit is for mounting GAI-Tronics telephones on to the side of round poles of 100mm to 200mm diameter, or on to square or rectangular section uprights of 100mm to 150mm across the mounting surface. For flat mounting on surfaces greater than 150mm across use the desk or wall mounted methods as appropriate.

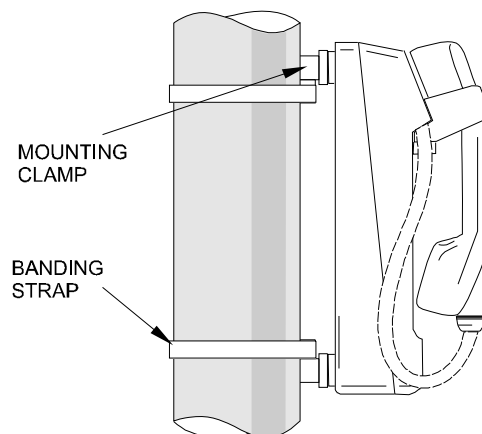

Figure 3 – Pole side mounting

NOTE:

Banding straps (large scale worm-drive clamps) are not included in this kit and must be obtained separately. For details of where mounting kits can be obtained, refer to GAI-Tronics .

1. Remove rubber feet from the Rear Casing if fitted. Attach the pole mounting clamp assemblies to the Rear Casing using the M6 x 25 screws provided.
2. Ensuring that the glands are at the bottom, pass a proprietary banding strap round each of the pole mounting clamps and the support pole. Tighten securely.
3. Continue the installation procedure with the connection of individual wires from the cable as described under sections 2.7 onwards.
4. Secure the telephone Front Casing to the Rear Casing.

5. Re-tighten the straps firmly and trim off any excess band material.
For security the driving head of the band may also be sawn off.

2.6 Desk Mounting / Rake

IMPORTANT WARNING:- Risk of impact or falling

This telephone, when used in a desk mounting mode, should be located on a horizontal, flat non-slip surface. Due to the heavy and robust construction of the unit, users must take care when using the handset or headset, not to pull the cord to such an extent as to cause the telephone to be pulled off the flat surface, and possibly cause damage or injury to persons or equipment. Therefore it is recommended that the unit be fixed in position using fixing positions and method detailed in section 2.4 if there is any risk of the unit being dislodged as described above.

To provide a 'rake' for convenient operation, the Front Casing may be turned through 180° before it is fitted to the Rear Casing. Thus the cable entries are at the rear of the telephone.

1. Ensure that the supplied rubber feet are fitted to the underside of the Rear Casing if the telephone is not fixed into position.
2. Rotate the Front Casing through 180° and fold the keypad ribbon cable to ensure that it lays flat against the potted block when re-assembled. Refer to Figure 9 - Ribbon cable positions (page 21)
3. Continue the installation procedure with the connection of individual wires from the cable as described in sections 2.7 onwards.

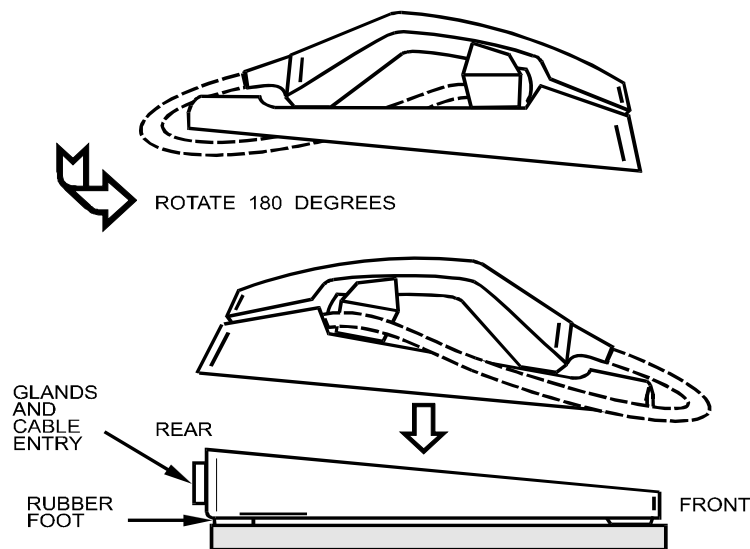

Figure 4 - Providing the rake

2.7 Connections and Cabling

IMPORTANT WARNING:-

ISOLATE MAINS AND TELEPHONE LINE OUTSIDE THE HAZARDOUS AREA BEFORE OPENING THE CASE.

ALL TERMINALS MUST BE CONNECTED IN ACCORDANCE WITH THIS INSTALLATION GUIDE. ANY DEVIATION FROM THIS MAY RESULT IN AN UNSAFE INSTALLATION AND VIOLATE THE CONDITIONS OF THE CERTIFICATE.

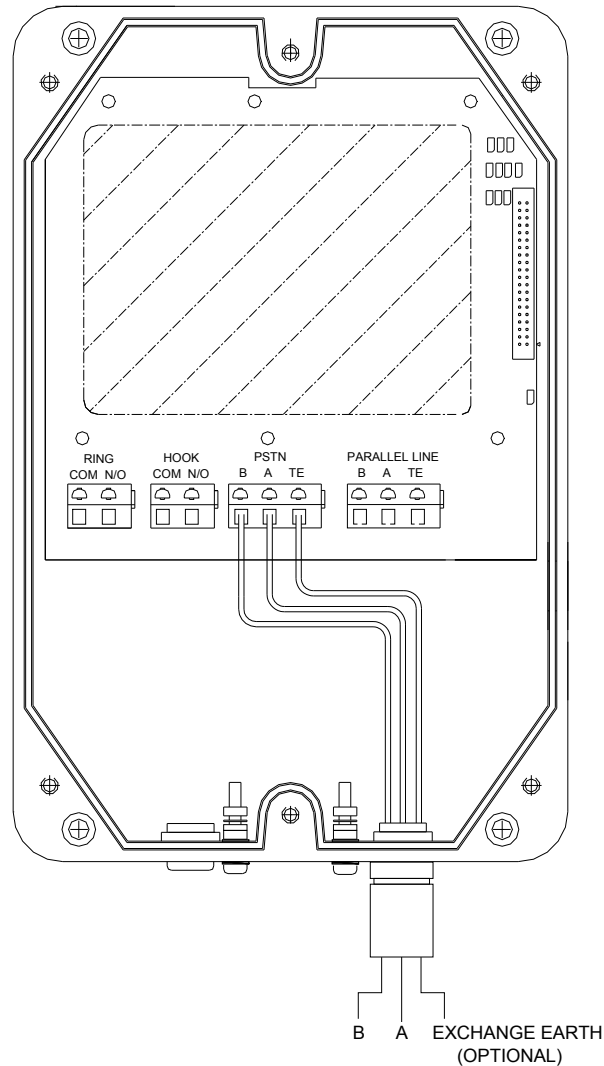

Figure 5- telephone line connections - telephone line only

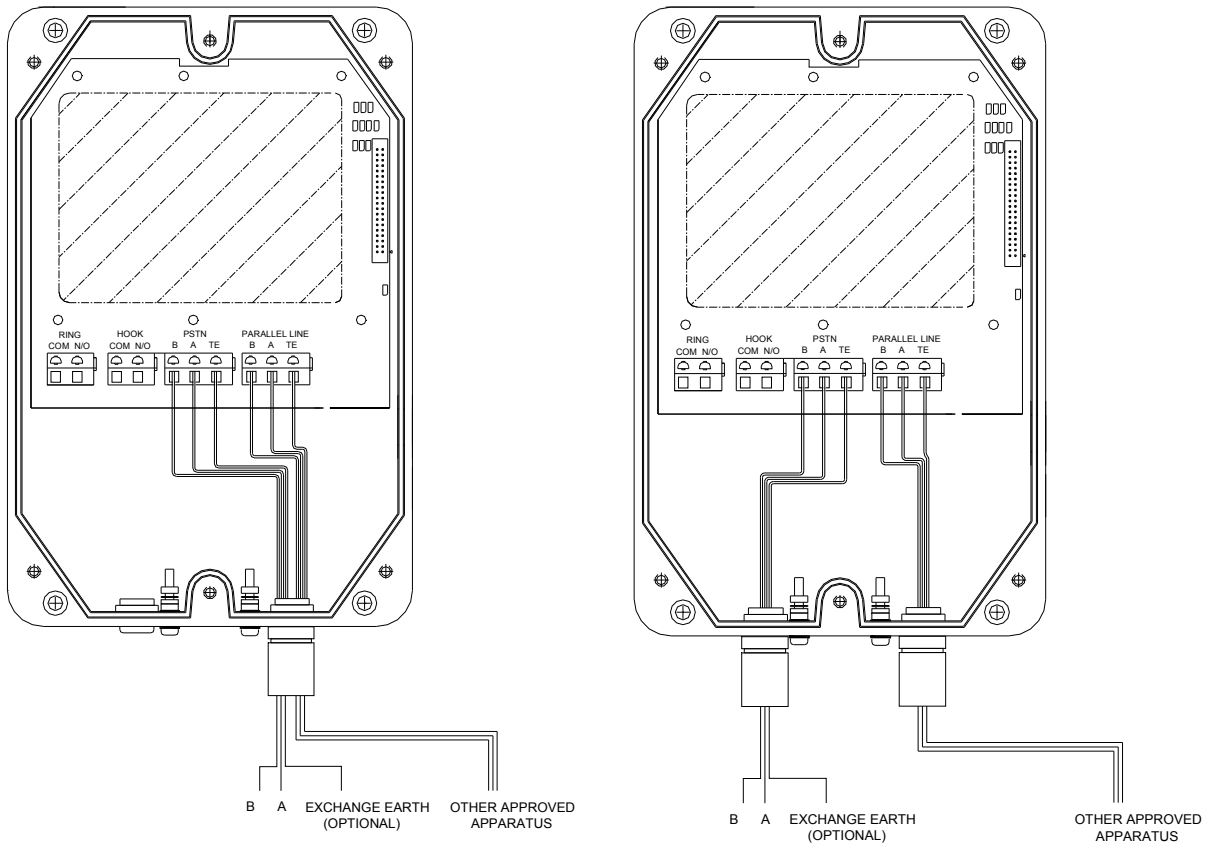

Figure 6- telephone line connection + parallel connection (alternatives)

2.7.1 Connection to a TELECOMMUNICATIONS NETWORK

To maintain safe operation of this product the telephone line must not exceed the following:

- **$U_m = 250V$ rms**
- **Rated voltage = 70Vdc + 100Vrms Ring Voltage**
- **Maximum power = 15W (in accordance with EN60950:2000 Clause 1.4.11 and 1.2.13.8)**

Note: these are safety parameters only and correct operation under these conditions is not implied.

For correct operation the telephone line should comply with the following:

- Ring Voltage: 30V to 100V rms, 20Hz to 50Hz
- Line voltage 20 to 70 Vdc
- Loop current $\geq 15mA$

2.7.2 Ring Relay Contact

(Galvanically isolated, volt-free contact)

The connection from the telephone to the external load must be installed such that the apparatus continues to comply with the requirements of EN 60950:2000.

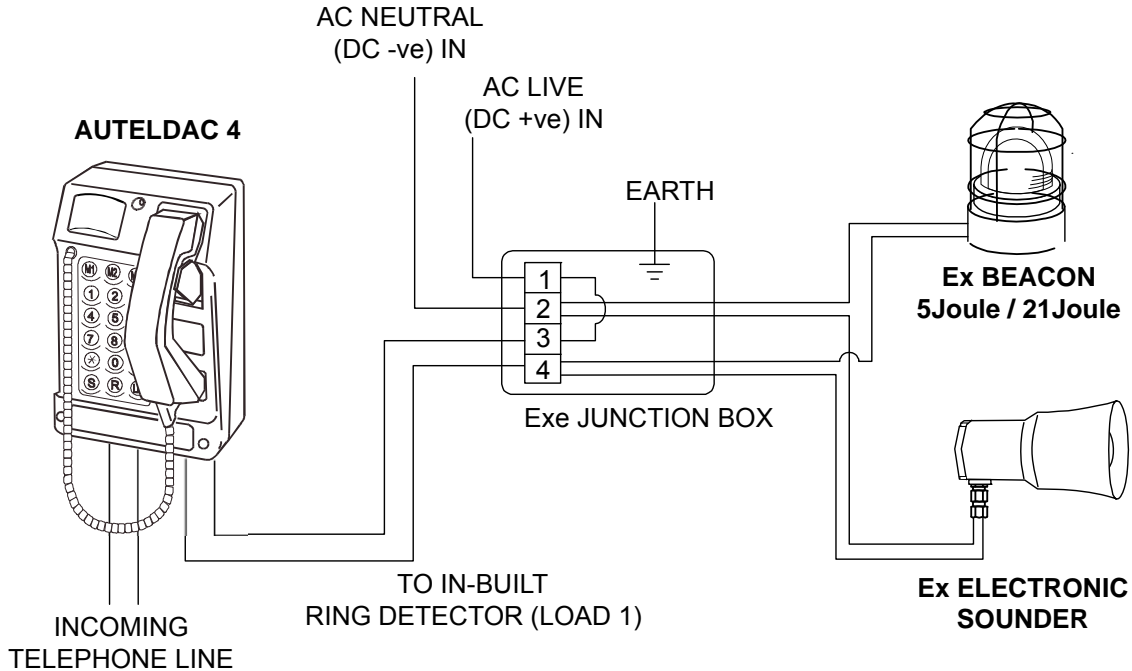

Typical connection scheme for a sounder and beacon.

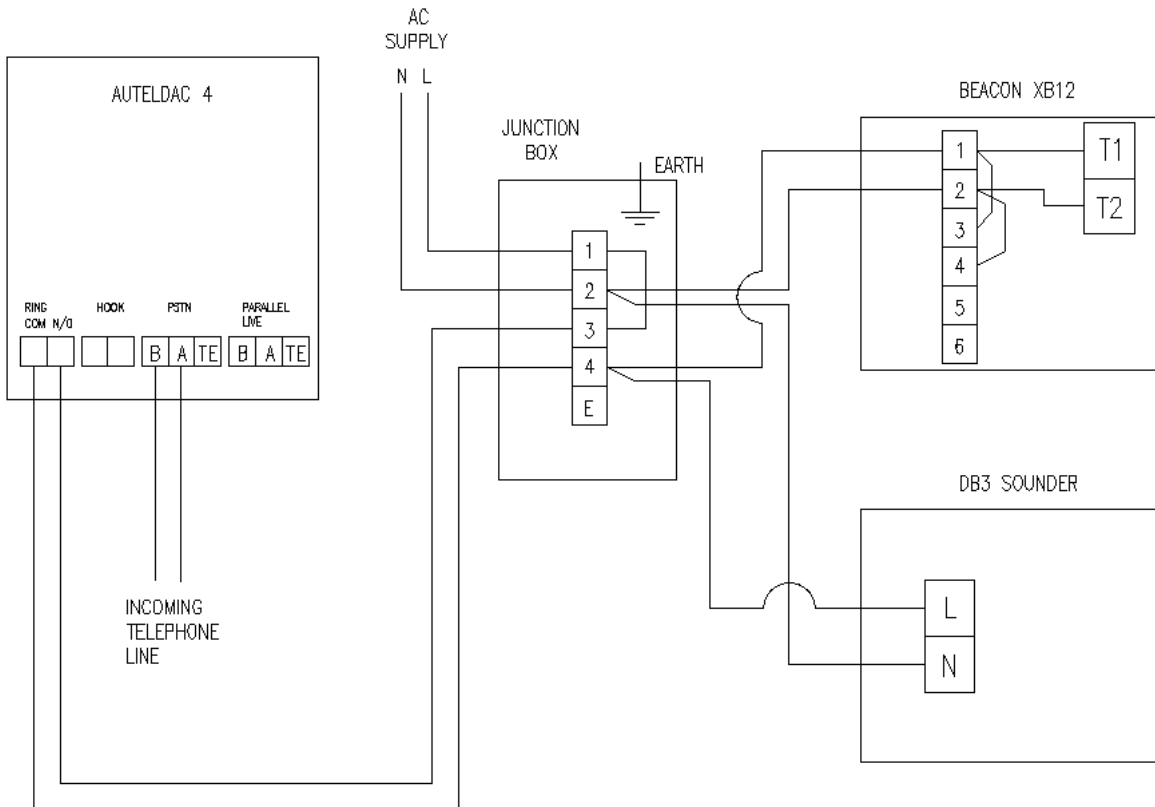

Telephone connection diagram

Maximum voltage = 240Vrms

Maximum current = 5A

Note: no fusing or transient protection is provided; this must be installed externally.

Note: The minimum ring voltage required to operate the ring relay depends on the frequency of the ring signal and on the loudness setting of the Auteldac 4 ringer. Approximate minimum values (in V rms) are shown in the table below:

Volume setting	Ring frequency (Hz)	
	50Hz	25Hz
Quiet	35	39
Medium	36.5	40
Loud	39	46
V. Loud	54.5	62

The ring detect relay fitted to the Auteldac 4 has a continuous current rating of 5A. It has been brought to our attention that some beacons, whilst having a current rating well below this figure, actually generate current spikes far in excess of this during making and breaking of the relay contacts. These current spikes can cause the relay contacts to fail.

GAI-Tronics have been working closely with Beacon manufacturer, MEDC, to resolve this issue and our recommendations are:

- Restrict the use of beacons to non AC variants only or those with a maximum flash intensity of 5 joules.
- Where beacons with greater than 5 joule flash intensity are required, the beacons should be purchased direct from GAI-Tronics, who will carry out a free of charge modification to the beacon to ensure compatibility with the Auteldac 4 and to maintain ATEX approvals.
- Utilise only beacons with integral ring detector, so that the relay in the Auteldac 4 is not needed to activate the beacon.

2.7.3 Hook Switch State Indicator Contact

(Optically isolated, volt-free contact)

The connection from the telephone to the hook switch state indicator must be installed such that the apparatus continues to comply with

the requirements of EN 60950:2000

Maximum voltage = 240Vrms

Maximum current = 150mA

Note: no fusing or transient protection is provided; this must be installed externally.

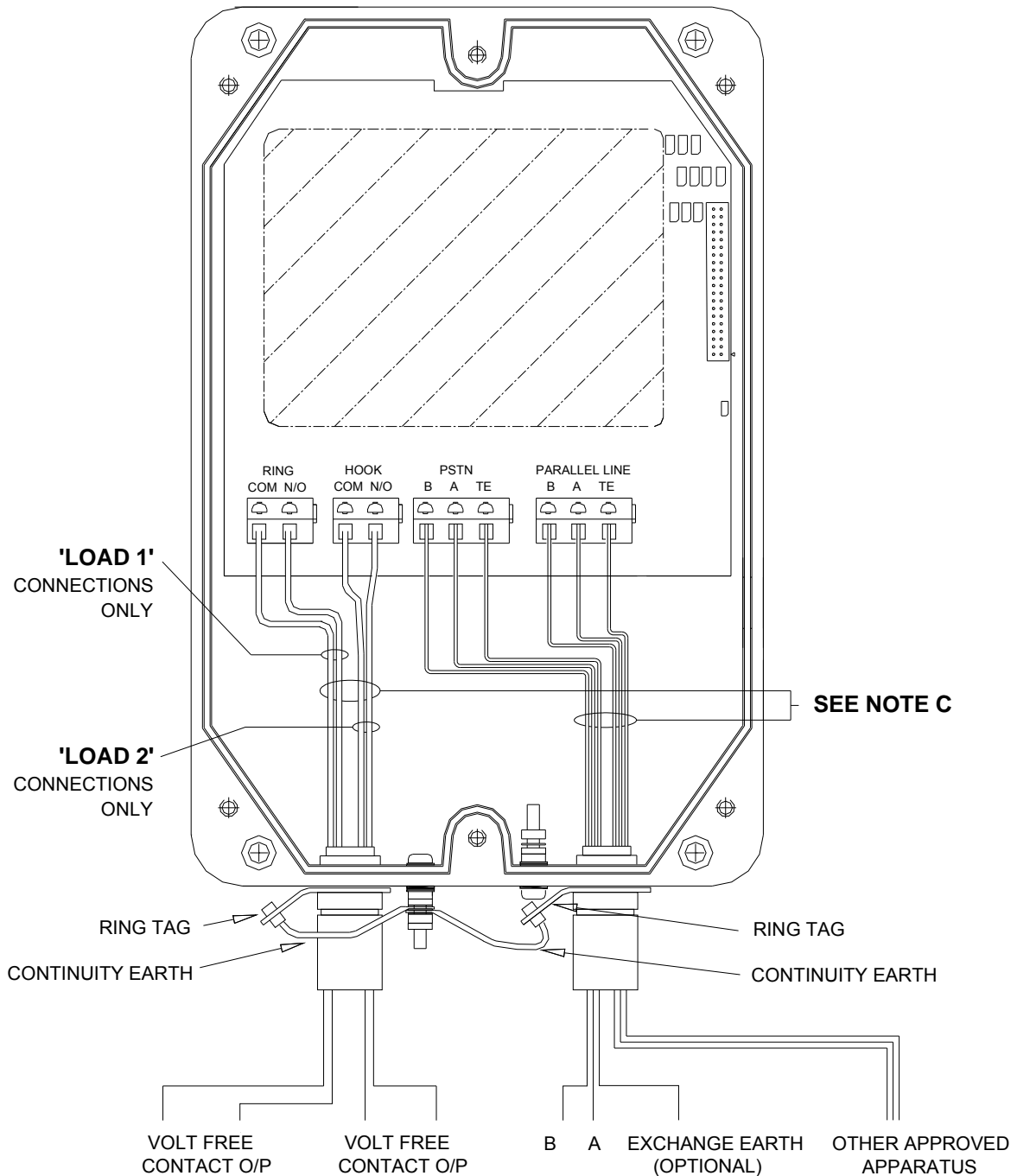

Figure 7 – Wiring for telephone and external loads

NOTES:

A: Conductor sizes to be $0.5\text{mm} - 2.5\text{mm}^2$.

B: INSULATION THICKNESS ON ALL CORES TO BE 1mm MINIMUM

C: Ensure these two sets of cable are segregated

2.8 Option Settings

Auteldac 4 has four functions that have optional settings. These are set using jumpers on the main circuit board as described below.

ISOLATE MAINS AND TELEPHONE LINE OUTSIDE THE HAZARDOUS AREA BEFORE OPENING THE CASE.

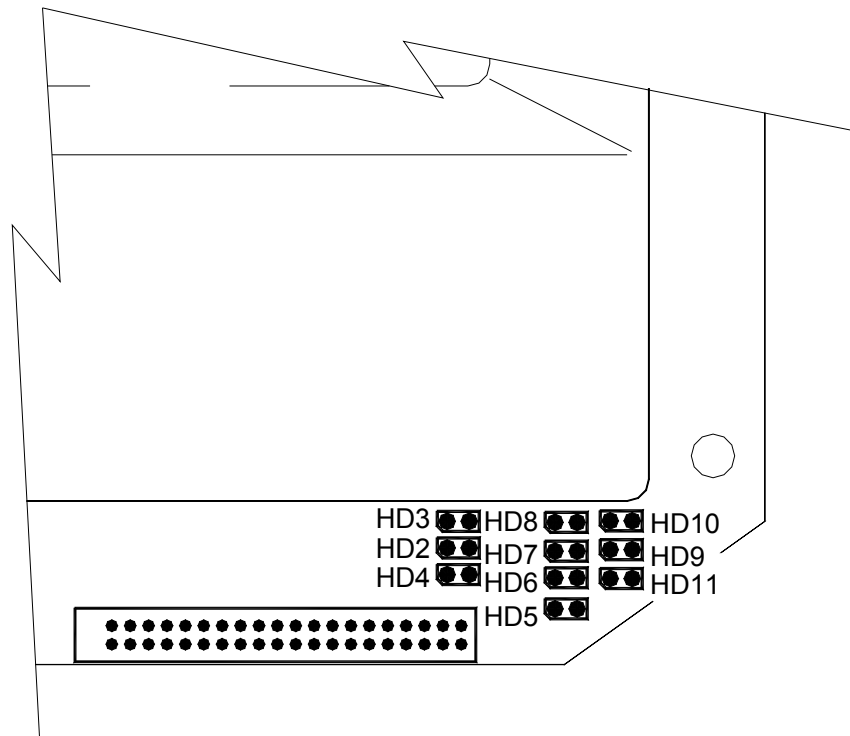

Figure 8 - Option jumper positions

2.8.1 Dialling method

Select the required dialling mode by fitting the jumper to one of the headers below as appropriate:-

- Tone dialling (87ms/87ms burst/pause time) – HD2
- Pulse dialling (10pps), make/break 40ms/60ms– HD3
- Pulse dialling (10pps), make/break 33ms/66ms– HD4

2.8.2 Recall Mode

Select the required recall mode by fitting a jumper to one of the below headers as appropriate:-

- Timed Break Recall (98ms) – HD5
- Timed Break Recall (250ms) – HD6
- Timed Break Recall (604ms) – HD7
- Earth Loop Recall (600ms pulse) – HD8

2.8.3 Ringer Loudness

Select the required ringer volume by fitting the jumper to one of the below headers as appropriate:-

- V.LOUD (>90dBA) – HD11
- LOUD (approx. 85dBA) – HD10
- MEDIUM (approx. 75dBA) – HD9
- QUIET (approx., 65dBA) – no jumper on HD9-11

IMPORTANT WARNING: Ringer high noise level hazard:

Note: the telephone ringer can develop a sound level in excess of 90dBA @ 1 metre. Therefore, it is the installer's responsibility to take the necessary measure to comply with the European directive 2003/10/ec on the minimum health and safety requirements regarding the exposure of workers to the risks arising from physical agents (noise).

2.8.4 Call Timer

Fit a jumper to the ON position (Figure 6), to enable the timer (6 minutes nominal). Fit the jumper to the OFF position to disable the timer.

2.9 Assembly of Telephone on to Installed Base

1. Ensure that the keypad connection between the base and the keypad PCB is made observing the correct orientation of the connector. A keyway on the connector facilitates ensuring that the ribbon cable connector is correctly orientated. Do not forcibly fit the connectors

IMPORTANT – FAILURE TO ENSURE THE CORRECT ORIENTATION OF THE CONNECTOR WILL VIOLATE THE CONDITIONS OF THE CERTIFICATE

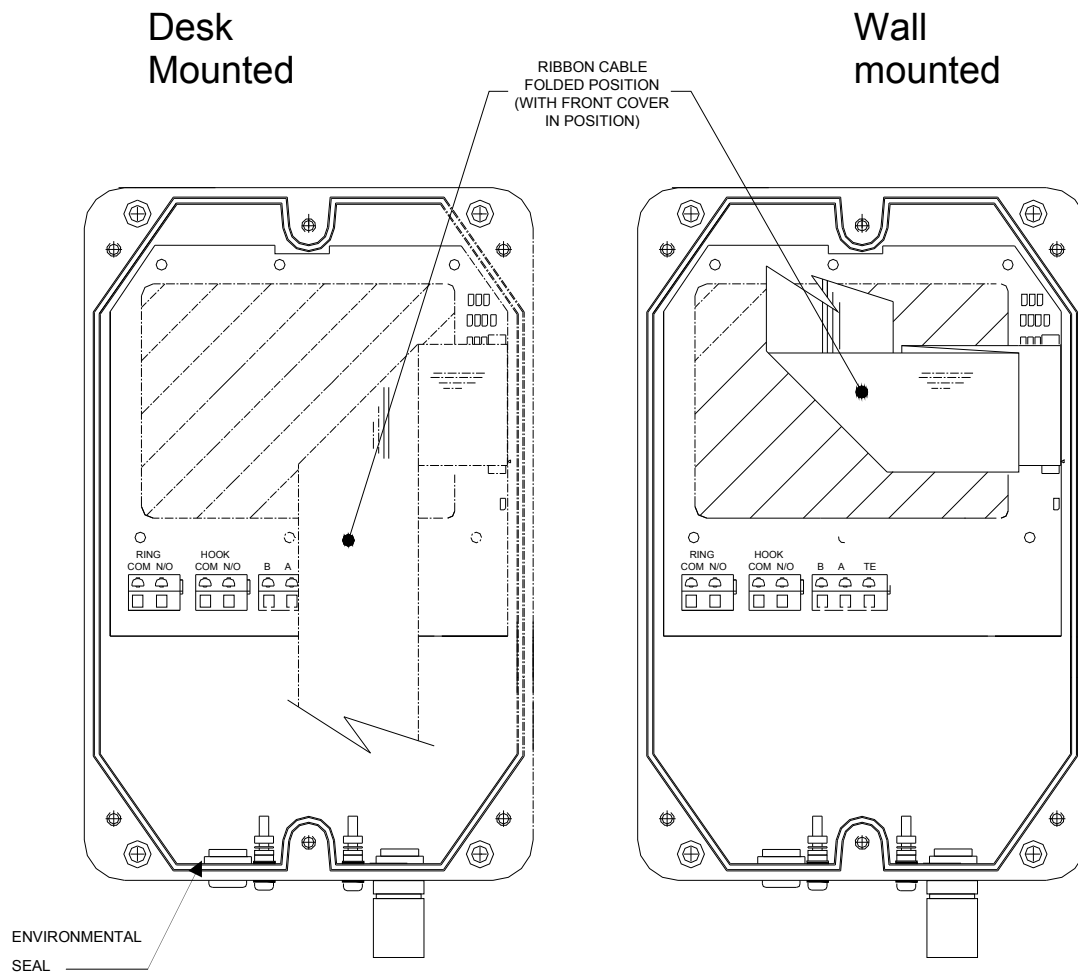

Figure 9 - Ribbon cable positions

2. Offer the Front Casing to the Rear Casing, with the ribbon cable appropriately folded as shown in figure 8; ensure that the cable will not be trapped when the Front Casing is tightened down. Take care that all folds are made, the ribbon cable can lay flat and that the insulation can not become damaged.

IMPORTANT - DAMAGED INSULATION WILL VIOLATE THE CONDITIONS OF THE CERTIFICATE.

Check also that the environmental seal is in position.

3. Tighten the three securing screws firmly.

2.10 Possible Operating Faults

The following operating and installation conditions could give rise to faults. During installation, or in the event of a fault, please ensure that the following do not occur:

- Incorrect position of headers (Section 2.8)
- Water ingress
- Incorrect positioning of ribbon cable (Section 2.9)

- Damage to any internal components
- Overstressing of screws
- Insecure fixing
- Incorrect installation of glands (Section 2.3)
- Incorrect wiring or cable connections (Section 2.7)
- Improper reassembly following connection
- Additional holes drilled in casing

3 OPERATION

Note that features may vary according to the model supplied.

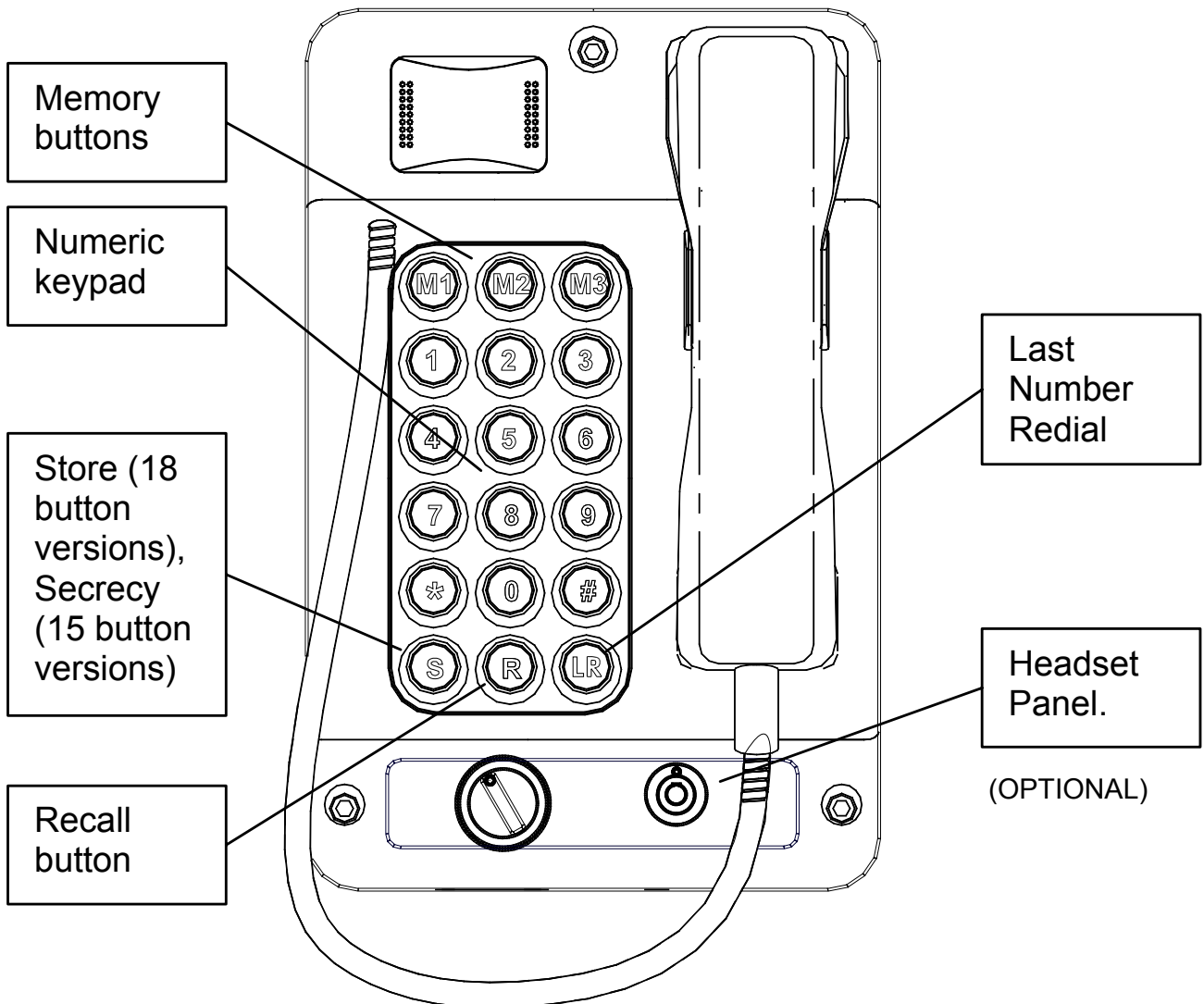

3.1 Making and Receiving Calls

- To make a call, lift the handset, wait for dial tone, dial required digits (or press required memory button or Last Number Redial where fitted) and wait for connection.
- For CB versions (i.e. no buttons are fitted), no dialling is possible – the call must be connected by the exchange sensing the telephone off hook.
- To end a call, replace the handset in its cradle.
- To receive a call, lift the handset when ringing is heard.
- Take care, when using either the handset or optional headset, not to allow cables to tangle or snare around the body or neck.

3.2 Last Number Redial

(15 and 18 button versions only)

Press LR to redial the last dialled number.

3.3 Recall Function

(15 and 18 button versions only)

Press R to send a “recall” signal to the exchange. The type of recall can be selected (see section 2.8.1).

3.4 Programming

(18 button versions only)

The three memory buttons, M1, M2 and M3 may each be programmed with up to 17 digits for one touch memory dialling.

To program a number:

- Lift the handset
- Press S
- Enter the required digits
- Press S again
- Press the required memory button, M1, M2 or M3
- Replace the handset

3.5 Secrecy or Mute Function

(15 button versions only)

During a call, press and hold the S button to mute the microphone.

3.6 Headset Operation

(refer to section 2.2.1 for hazard warning)

The Auteldac 4 can be supplied fitted with a headset option, permitting hands-free operation. Only use the approved GAI-Tronics supplied headset and headset extension cable.

To use:

1. Insert headset plug into marked connector, observing keyway.
2. To make or answer a call, turn the switch to the 'I' position.
3. To terminate the call, turn the switch to the 'O' position.
4. To remove the headset, pull the body of the connector to release the latching mechanism. Do not attempt to disconnect the headset by pulling the cable as damage may result.

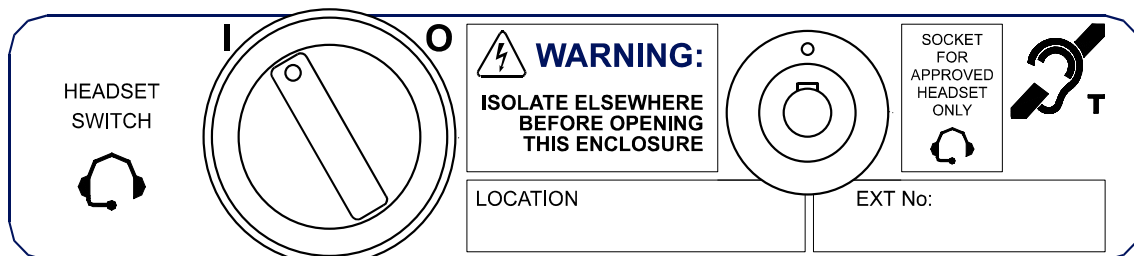
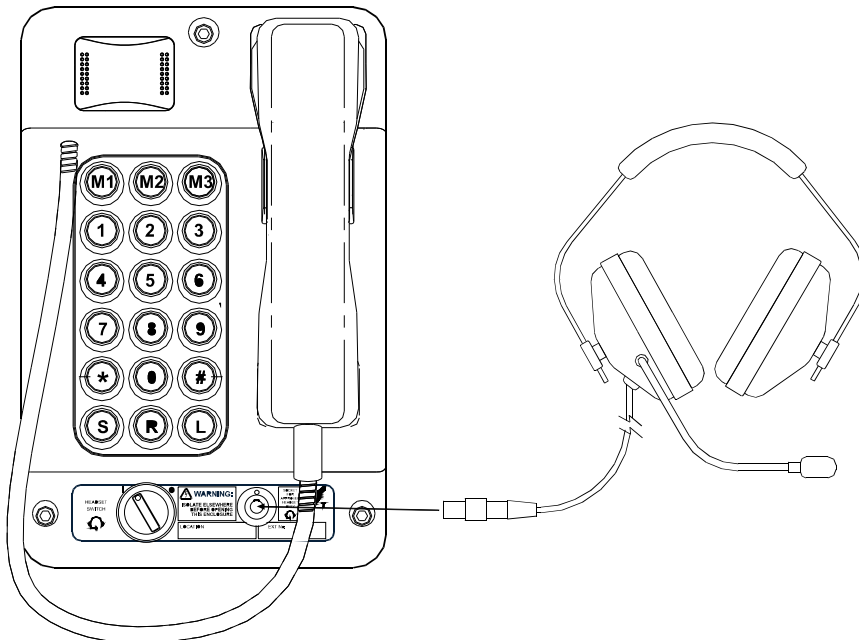

NOTE: If the handset is lifted during a call using the headset, the handset microphone will be muted. The handset can be used normally if a call is not in progress via the headset.

The headset must be used in accordance with the manufacturer's manual (supplied with headset).

The Auteldac 4 headset interface has been certified as intrinsically safe. Therefore, it is permissible to connect and disconnect the headset in a hazardous area.

4 MAINTENANCE

The Auteldac 4 is based on highly reliable integrated circuits. Under normal operation, the telephone is maintenance free.

4.1 Procedures

A programme of regular external visual inspection and cleaning is recommended, with particular attention being paid to -

On all models:

- Overall cleanliness of the telephone:
Wipe clean as necessary with a cloth dampened with clear water. If heavily soiled, a little dishwashing liquid may be used in addition.
NOTE: high pressure hoses should not be used for cleaning.
- Security of the installation on wall, pole or post.
- Security and integrity of cable entries.
- Security of the three body screws.
- Cleanliness, integrity and condition of the handset:
Wipe clean as necessary with a cloth dampened with clear water, and disinfect the handset.
Note that the handset has an anti-static coating – take care not to damage this by excessive rubbing or the use of chemicals or solvents (e.g. petroleum spirit). Do not allow liquid to penetrate the earpiece or mouthpiece.
- Security and condition of the handset cable.
On headset models, refer to headset manufacturer's manual for cleaning, hygiene and maintenance of headset.

4.2 Fault Finding & Field Repairs

The Auteldac 4 contains no user serviceable parts and in the event of damage or failure must be replaced with a tested telephone of the correct type.

Refer to section 2.10 for a list of possible fault conditions.

5 CE DECLARATION

GAI-Tronics

A Division of Hubbell Ltd

Declaration of Conformity

We, GAI-Tronics (a division of Hubbell Ltd.), of Brunel Drive, Stretton Business Park, Burton upon Trent, Staffordshire, England, DE13 0BZ, declare under our sole responsibility, that the following product is in conformity with the directives and standards listed below and hold the relevant technical documentation at the above address.

Product description	IECEX & ATEX Approved Hazardous Area Telephone Auteldac 4
Product part number range	212-02-2XXX-XXX

EC Directive	Standards applicable under the Directive
1999/5/EC Directive (R&TTE) Radio & Telecommunications Terminal Equipment. Equipment or Protective System Intended for use in Potentially Explosive Atmospheres Directive 94/9/EC.	EN55022:1998 Information Technology Equipment. (EMC) EN55024:1998 Information Technology Equipment. (EMC) EN 60950:2000 Information Technology Equipment. Safety I-CTR 37/ CTR 38 Pan European ETSI Handset EN60079-0:2007 - Electrical apparatus for explosive gas atmospheres Part 0: General requirements. EN60079-7:2007 - Electrical apparatus for explosive gas atmospheres Part 7: Increased safety 'e'. EN60079-11:2007 - Electrical apparatus for explosive gas atmospheres Part 11: Protection by intrinsic safety 'i'. EN60079-18:2004 - Electrical apparatus for explosive gas atmospheres Part 18: Construction, test and marking of type of protection encapsulation 'm' electrical apparatus.
2002/95/EC - Restriction of the use of certain hazardous substances in electrical and electronic equipment (RoHS)	Complies
2002/96/EC 2003/108/EC Waste Electrical and Electronic Equipment Directive (WEEE)	Complies

Notified Body	Baseefa, Rockhead Business Park, Staden Lane, Buxton, Derbyshire UK. SK17 9RZ 1180
Identification Number	1180
EC Type Examination Certificate Number	Baseefa03ATEX0617 Telephone Group II, Category 2 G (Ex e ib mb IIC T4 (-20°C ≤ T _a ≤ 55 °C)) Group II, Category 2 G (Ex e ib mb IIC T5 (-20°C ≤ T _a ≤ 50 °C)) Telephone with Headset Group II, Category 2 G (EEx e ib IIC T4 (-20°C ≤ T _a ≤ 40 °))
IECEX Examination Certificate Number & Markings	IECEX BAS 05.0060 Ex e mb ib IIC T4 Gb (-20°C ≤ T _a ≤ 55 °C)) Ex e mb ib IIC T5 Gb (-20°C ≤ T _a ≤ 50 °C))

Date of issue	Name of authorised signatory	Signature of signatory
2 nd Feb 2011	G Lines Business Unit General Manager	

GAI-TRONICS

A division of Hubbell Ltd.

Brunel Drive

Stretton Park

Burton upon Trent

Staffordshire

DE13 0BZ

www.gai-tronics.co.uk

Tel: +44 (0)1283 500 500

Fax: +44 (0)1283 500 400

If you have any difficulties, please call.

The policy of GAI-Tronics is one of continuous improvement,
therefore the Company reserves the right to change
specifications without notice.

The contents of this publication are confidential, are the property of GAI-Tronics, and may not
be reproduced, wholly or in part, without their written permission.

E&OE.