



Sentinel

Hands Free Weather Resistant Telephone



- Full keypad with remote programming
- DTMF/LD dialling
- Line powered down to 25mA
- Optional mains supply adapter
- Hands free operation (VOX)
- Non-volatile memory store
- Audio-visual ring indication
- Flush or surface mounting
- Volume adjust on installation and on front panel
- CE compliant (SMART option tested to CTR 21)
- Optional variant available with SMART (Self Monitoring And Reporting)

The Sentinel family of telephones is fully electronic, ruggedised and weather resistant, and incorporates many features found on modern commercial telephones. It provides hands free loudspeaking communications such as intercom PBX switching or can be coupled directly to the UK telecom network.

Sentinel is flush or surface mounted and designed to be fixed to a vertical surface by vandal resistant tamperproof screws. The combined key pad and faceplate is weather resistant and depending on suitable interface sealants, has an IP rating of up to IP65 depending on how it is mounted.

The internal components are protected by a weather resistant enclosure behind the faceplate.

Incoming calls are indicated by a flashing LED and audible warble tone. To aid intelligibility, a volume control button is provided for noisy environments.

Call termination can either be through button depression, automatic time out or remote command.

Ringer operation is selectable either at installation or as remote programming.

Keypad Diallers:

Available as 18 button with 2 memory keys and volume (VOL) button, the sentinel can be configured to be fully compatible with most PABX's or PTT networks. Loop disconnect (LD) and Tone dialling (DTMF) systems are internally selectable, as are a variety of recall systems, Time Break Recall (TBR) and Earth Loop Recall (ELR).

SMART Option:

Self-Monitoring And Reporting Telephone optional variants are available, please call.

DAC Telephony

Sentinel

Hands Free Weather Resistant Telephone

TECHNICAL SPECIFICATIONS

Speech:

Tested to the CTR21 specification.
Voice-switched (VOX) semi-duplex operation.
Additional half-duplex mode controlled remotely (optional local push-to-talk button).
Send & Receive levels remote programmable (1dB step)
Receive volume control button(s) adjusts level by +/- 6dB.
Call timeout programmable from 1 to 42 minutes.
Remote switch-off capability.
Euro-wide network matching (factory set).

Dialling Data:

LD impulse rate : 10 ips
Mark/space ratio : 2:1
MF dialling tones meet international standard requirements CCITT Q23.
Initial dialling and recall modes: DTMF or LD, TBR or ELR, Mute-Before-Dial (remote programmable).
Other formats (factory set):
DTMF: 50ms or 100ms.
LD: 66:33 / (60:40 option factory set) 500ms / 800ms idp
TBR: 100ms, 300ms or 600ms.
Full keypad with 2 memories, Recall and Volume button.
Up to 10 memories: 24 digits maximum with embedded Recall, Pause, Pulse & Tone characters.

Safety: Tested to EN41003 and EN60950.

Ringing and Remote Maintenance:

Dual tone ringing through loudspeaker >75 dB @ 1m REN 1.
Auto-answer for remote programming: 0 to 15 rings.
Speech disabled during remote programming: call cleared down in favour of user dialling.

Sensing: Remote sensing of network loop current (2.5 mA resolution) and power-supply connection.

The keypad can be remote scanned to determine any button press.

Power Supply: Line powered only operation down to 25mA. Supplementary power 9-12Vdc 250mA. Below 35mA line current supplementary power is recommended to achieve full volume.

Memory Retention (autodiallers): E² PROM - 10 year life.

Temperatures:

Operating: -20° C to +60° C

Storing: -40° C to +70° C

Relative Humidity: Up to 95% (non-condensing).

Weather Resistance: Up to IP65 dependent on installation.

Please call for advice on application.

Casing Material: Front face plate mounting: aluminium sheet, polyester powder coat finish - grey, yellow. Call for other options. Rear enclosure (if required).

Keypad: Weathersealed tactile, silicon.

Weight: 1.1kg (3kg with backbox)

DIMENSIONS:

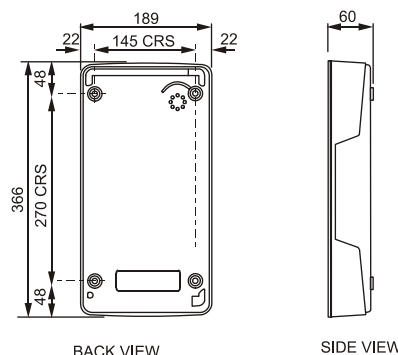
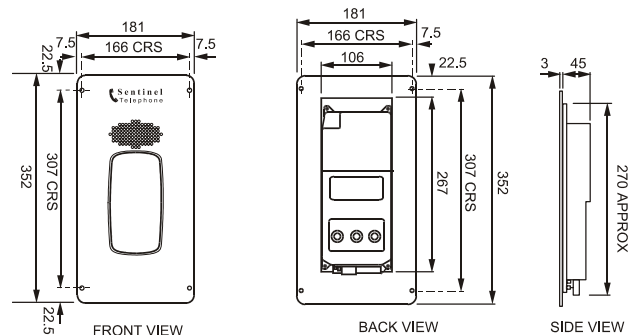

APPROVALS



This mark indicates compliance with the following directives: Radio & Telecommunications Terminal Equipment Directive 1999/5/EC (R&TTE)



Optional Induction Loop for hearing impaired

This mark indicates compliance for inductively coupling to Hearing Aids having a 'T' switch position
Tested to ETS 300-381 and in accordance with ITU-T P37.

For specific country approval, please call

ORDER CODE

18 Button

2100A331113142

OPTIONAL ACCESSORIES ORDER CODE

Please ask for Brochure B150 or visit www.gai-tronics.co.uk



GAI-Tronics, UK - Tel: +44 (0)1283 500500 - Fax: +44 (0)1283 500400 - www.gai-tronics.co.uk

GAI-Tronics Corporation, USA - Tel: +1(610) 777 1374 - Toll Free: 800 492 1212 - Fax: +1(610) 775 6540 - www.gai-tronics.com

GAI-Tronics S.r.l., Italy - Tel: +39 02 48601 460 - Fax: +39 02 4585 625

GAI-Tronics Corporation, Malaysia - Tel: +60 3 8945 4035 - Fax: +60 3 8945 4675

An ISO9001 Registered Company

The policy of GAI-Tronics is one of continuous improvement, therefore the company reserves the right to change specifications without notice.

B031-4-0704B/CN21758