



Titan

Metal Bodied Weather Resistant Telephone



- **Standard and SMART Analogue and VoIP-SIP options available**
- **Vandal Resistant Handset and Cord**
- **Robust and weather resistant: IP54 to IP66**
- **Full keypad, full keypad with memory, CB and 1, 3 and 6 button programmable autodialler telephones**
- **Multi purpose design for wall or post mounting, simple installation**
- **Large tactile buttons, easy to see and operate**
- **Inductive Coupler fitted as standard for hard of hearing**
- **Standard or customised units**
- **CE Compliant**

Titan's aluminium body is robust and designed to look good and last longer in hostile outdoor environments. Along with weather and vandal resistance, the Titan range meets the acoustic performance, reliability and varying applications demanded by today's markets.

Titan is simple to install with fixings concealed from view giving increased security from vandalism. Cable entries are via water-tight glands while push buttons are weather sealed. Its spring loaded door also gives extra weather protection to the telephone. Connectivity options are:

Standard Analogue

The standard analogue unit provides basic telephone functions and can be connected to any standard two-wire telephone line, including FXS ports, analogue PABX lines and PSTN.

SMART Analogue

Self Monitoring And Reporting Telephone can be integrated with GAI-Tronics' TMA monitoring and maintenance software and/or GAI-Tronics CMA call centre. SMART gives advanced features including remote programming, fault monitoring and call logging, all from a line-powered telephone capable of operating up to 7km from the exchange on a two-wire cable.

Voice over IP (SIP protocol)

For connection to a VoIP enabled network, GAI-Tronics VoIP-SIP telephones offer direct connection to LAN or WAN via RJ45 connector, including Power-Over-Ethernet (PoE) as standard. GAI-Tronics VoIP-SIP phones offer a wealth of additional features including real-time reporting via Syslog, and can be configured by web browser.

Keypad Options:

15 & 18 button Full Keypad

Included in the 18 button version, are 3 direct dial buttons for fast one touch dialling of pre-stored numbers or accessing low cost call facilities. The 15 and 18 keypad versions include: **S** 'Microphone mute' or 'Silence', **R** 'Recall', **LR** 'Last number redial'

1, 3 6 & 18 button Autodiallers

These models are programmable via an internal keypad. A microphone muting facility guards against unauthorised calls made with a remote MF tone pad. To make a call, simply lift the handset and press a single button. The pre-programme number (up to 24 digits) will then dial automatically.



0 button CB

This can be used to initiate a PABX 'hotline' or lift handset and wait for reply, where the PABX does the call routing/dialling. Autodial on handset lift also available.



As well as the standard Titan range, GAI-Tronics can supply specials to order with customised options.

Metal Bodied Weather Resistant Telephone

TECHNICAL SPECIFICATIONS

Casing Material

Die cast aluminium, epoxy powder coated. Colours yellow or grey or special order

Handset Material

Cyclopol (2850) with stainless steel spiral cord

Keypad

Weathersealed tactile digital keypad. Silicone rubber material, resistant to most chemicals and solvents

Temperature

Operating: -20° C to +60° C

Storing: -40° C to +70° C

Weather Resistance

Door open - up to IP65

Door closed - IP66

Ringing Tone

Shrill warble tone 80 dBA @ 1 metre typical

Hookswitch

Electronic / magnetic with no visible moving parts

Lightning / Transients

Protection to ITU-T k.21 enhanced levels

M.T.B.F.

Calculated to have an M.T.B.F. in excess of 50,000 hours using MIL-HDBK-217F Notice 2

Weight

Up to 5 kg depending on option

STANDARD ANALOGUE

Dialling

LD (pulse) or MF (tone). User selectable

Time Out

Enforces a fixed call maximum time limit to 6-8 minutes from lifting the handset. User selectable

Power supply

Drawn from telephone line

SMART (ANALOGUE)

All the features of the standard analogue unit plus:

Remote programming

Auto-dial numbers, time-out and dial mode can be programmed over the phone line either from a tone phone or from monitoring software (TMA).

Configuration

Remotely programmable via TMA

Remote monitoring

Remote health-check and fault reporting, including handset integrity, either on a call-in or polled basis. TMA required.

Call Logging

Records call time, duration and auto-dial number used. TMA required.

VOICE OVER IP - SIP

Connection type

RJ45 socket (inside sealed enclosure)

Power supply

External 48Vdc or Power-Over-Ethernet (PoE 802.3af compliant)

Call set-up Protocol

Session Initiation Protocol (SIP) (RFC 3261) only

Configuration

Via configuration file or web page. Static IP address provisioning or DHCP

External I/O

4 auxilliary inputs, 2 isolated relay outputs (1 capable of switching 230Vac)

Monitoring and reporting

Real-time over TCP/IP proprietary Syslog application

DIMENSIONS:

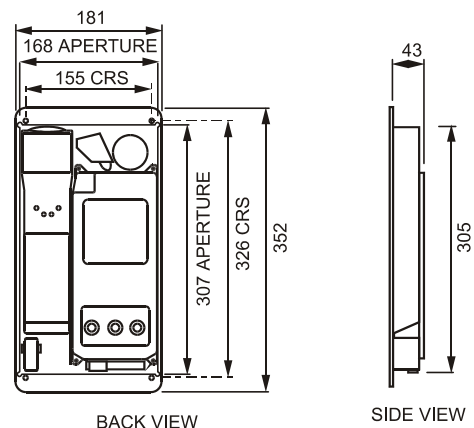
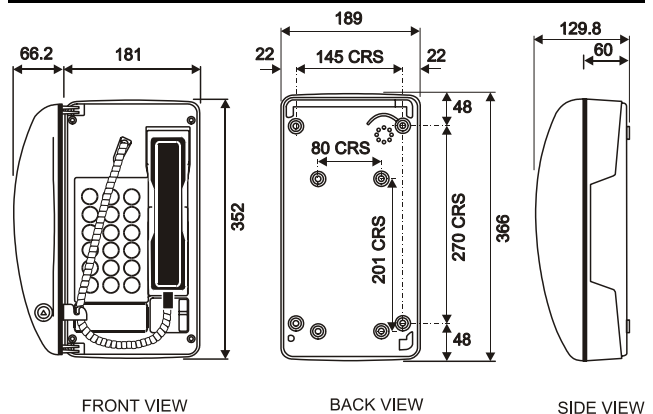

APPROVALS



This mark indicates compliance with the: Radio & Telecommunications Terminal Equipment Directive 1999/5/EC (R&TTE)



This mark indicates compliance for inductively coupling to Hearing Aids having a 'T' switch position. Tested to ETS 300-381 and in accordance with ITU-T P37.

For specific country approval, please call



GAI-Tronics is a CISCO Technology Developer Partner
Cisco IVT Tested

ORDER INFORMATION

T: 01283 500500, F: 01283 500400, E: sales@gai-tronics.co.uk

OPTIONAL TELEPHONE ACCESSORIES

Ask for Brochure B150 or visit www.gai-tronics.co.uk



GAI-Tronics, UK - Tel: +44 (0)1283 500500 - Fax: +44 (0)1283 500400 - www.gai-tronics.co.uk

GAI-Tronics Corporation, USA - Tel: +1(610) 777 1374 - Toll Free: 800 492 1212 - Fax: +1(610) 775 6540 - www.gai-tronics.com

GAI-Tronics S.r.l., Italy - Tel: +39 02 48601 460 - Fax: +39 02 4585 625

GAI-Tronics Corporation, Malaysia - Tel: +60 3 8945 4035 - Fax: +60 3 8945 4675

An ISO9001 Registered Company

The policy of GAI-Tronics is one of continuous improvement, therefore the company reserves the right to change specifications without notice.